

BEST IR System Breadboard Test Setup

Goal: To conduct simple tests and demonstration hookups for the BEST IR Kit using a solderless breadboard and test circuit.

Materials Needed

- BEST IR Sensor System (Assembled PCBs)
- 5V Power Supply
- Mini test hook probes (recommended)
- 3-wire cables (2)
- Solderless Breadboard and assorted jumper wires
- Few electronic components (resistors, transistor, LED, switch)
- Oscilloscope or frequency counter (optional)

This document will walk you through testing and debugging the BEST IR Circuit System's sensitivity and building a simple breadboarded test circuit for monitoring sensor activity.

Step 1: Separate the PC Boards

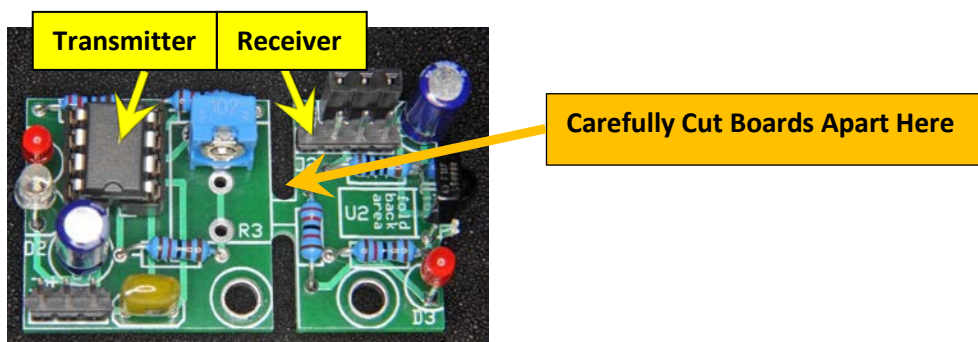

In the kit the two PC boards are manufactured as a single board to make it a little larger for easier assembly. After soldering on all the components, the two boards will be cut apart. If you have not already done so, cut the board as described in the final step of the assembly instructions.



The board that emits the IR light is the transmitter and is the larger of the two boards. The IR emitting diode is the clear one, located on one edge of the board. Note that as supplied it emits light in a direction perpendicular to the plane of the board. If you want it to emit light in the plane of the board, **carefully** bend the two leads 90 degrees, the IR diode will extend beyond the edge of the board.

The board that receives the IR light is the receiver and is the smaller of the two boards. The IR detecting IC is the dark, 3-legged device with a bump on its side, located on one edge of the board. The bump is a lens so the IR should shine on the bump. Note that as supplied it is “looking” in the plane of the board. If you want it to “look” in a direction perpendicular to the plane of the board **carefully** bend the IC back so the bump is away from the board. There is a clear area on the board that it should fit into without hitting anything.

Note that the leads on the IR emitting diode and IR detecting IC can likely only be bent one time without breaking the leads so you should think carefully before making your decisions on orientation.

The two large holes, one on each board, are for mounting and are sized for a #4 screw.

Step 2: Attach IR Sensor System to a Breadboard Test Circuit

This option offers more flexibility. The IR emitter can be controlled. The output of the RCV board can be monitored at a remote location (you don't have to be able to see the LED on the RCV board). It is suitable for simple signaling (on/off or pulse width) or a "beam break" application.

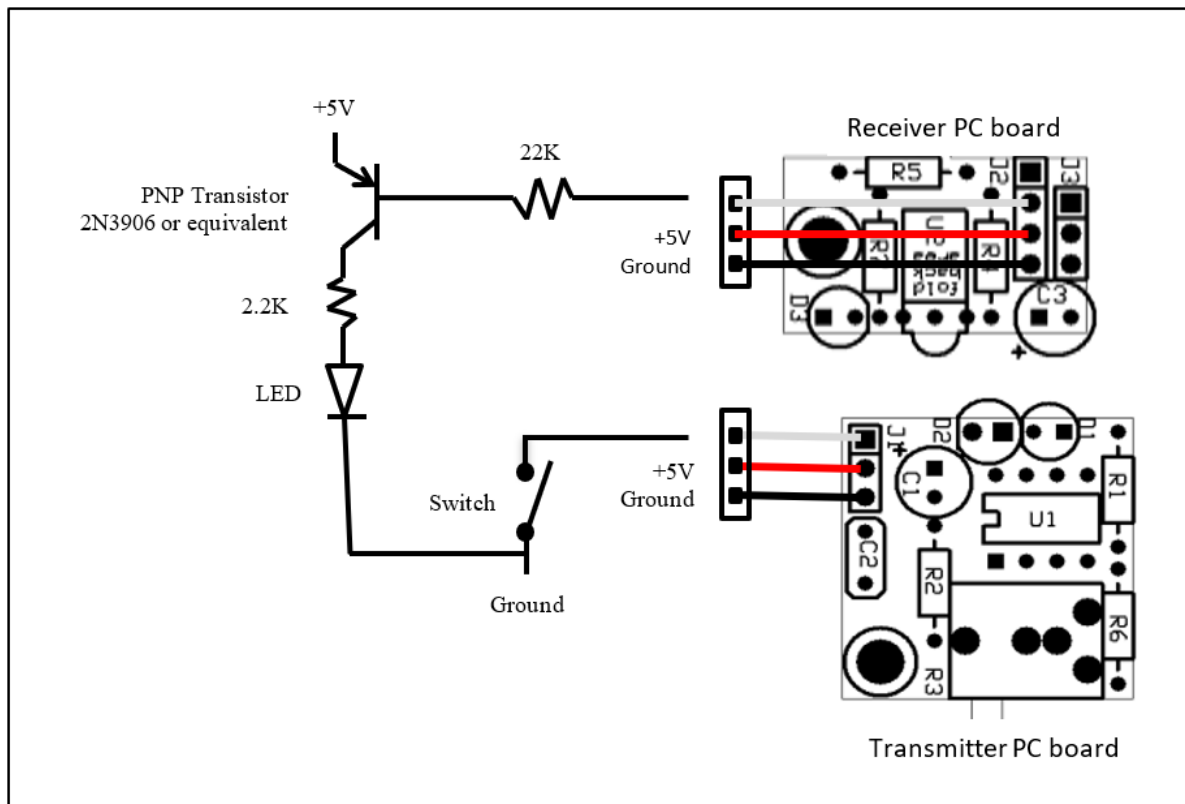

A More Versatile Test/Demo Hookup

Note: Be sure to get the polarity of the power supply correct.

Using a 3-wire cable, connect the power supply and switch to the XMT board. The male end of the cable connects to the power supply and switch. Using a solderless breadboard makes this a lot easier than trying to clip on to those tiny pins without shorting anything. The female end of this cable plugs onto the 3-pin connector on the XMT board, black wire closest to the bright yellow capacitor, away from the corner of the board.

Note: Be sure to get the polarity of the power supply correct.

Using a 3-wire cable, connect the power supply and circuitry to the RCV board. The male end of the cable connects to the power supply and thru a resistor to the base of the transistor. Using a

solderless breadboard is almost mandatory so you can add the rest of the components. The female end of this cable plugs onto 3 of the 4 pins on the RCV board, black wire on the pin closest to the dark, 3-pin IR detector IC. The 4th pin on the RCV board, the pin closest to the edge of the board, remains unconnected.

Component values are not critical. The LED can be any color you have handy. The transistor is any small general purpose PNP. The 2.2K current limiting resistor for the LED can be any value from about 1.5K to about 3K. The 22K resistor should be about 10x the value you use for the current limiting resistor. You can use any switch you like or even just a wire poked into a hole of your breadboard. ☺

Now when you close the switch the XMT signal will be turned off. The LED on the breadboard will be on when the RCV board detects a signal from the XMT board (the same as the LED on the RCV board).

The photo below is a sample solderless breadboard setup. Note that this breadboard uses a battery for power so it is quite portable. It also has an extra switch to connect the battery to the circuit.

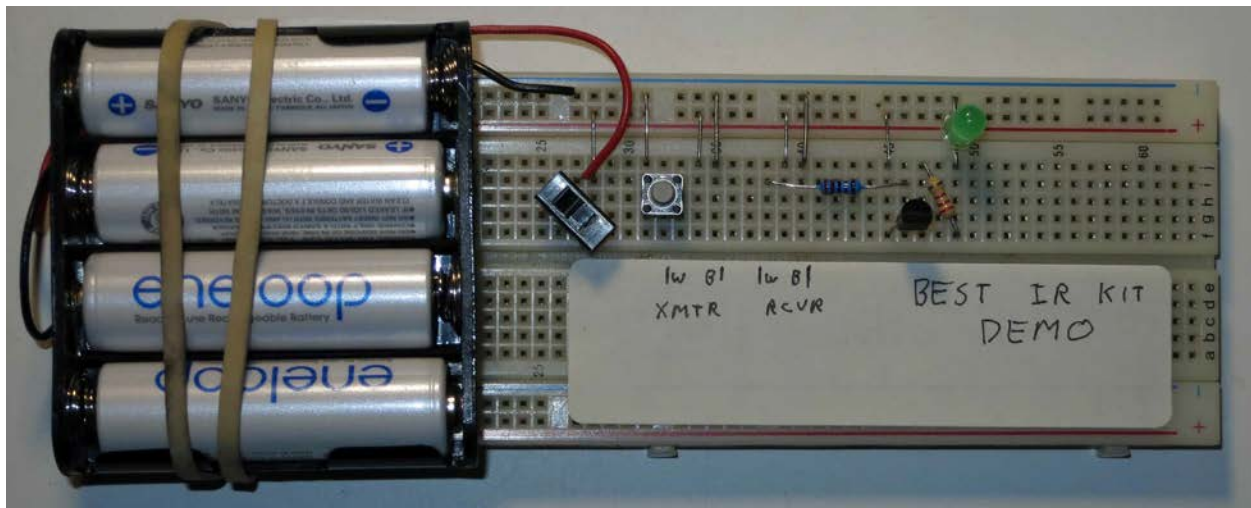

A Breadboard Implementing the Option 2 Circuit

Step 3: Adjust the System’s Sensitivity

For help in debugging, the transmitter board has a red LED that will be on when the IR emitter is on. The receiver board has a red LED that will be on when an IR signal is detected. Due to the limited power available, the receiver LED is fairly dim.

The IR signal is modulated at 38KHz to reduce sensitivity to other light sources – the detector is tuned to 38KHz and is less sensitive to constant light or other modulation frequencies. For maximum sensitivity tune the transmitter board to 38KHz. You can adjust the modulation frequency to adjust the system’s sensitivity by turning the white potentiometer on the transmitter board. There are a couple ways to make this adjustment.

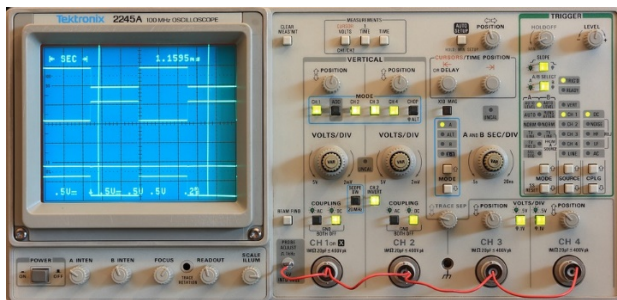

If you have an oscilloscope or frequency counter connect it to pin 7 of the 8-pin DIP to monitor the frequency. If you lack that equipment, don’t panic. You can do a pretty good job without any special test equipment. Separate the transmitter and receiver until the receiver just barely detects the IR signal. Now when you adjust the potentiometer you should find that the receiver detects the IR signal somewhere in the middle of its range of travel but does not detect the IR signal at either the counter-clockwise extreme or the clockwise extreme. Find the two spots of the potentiometer’s travel where it switches between detecting and not detecting and set the potentiometer halfway between these two points.

You may not want maximum sensitivity. Perhaps your transmitter and receiver are very close together, counting wheel spokes as they go past, for example. Frustratingly, it doesn’t work reliably because the receiver is also picking up reflections from other parts of your robot. In this case you can “detune” the transmitter so that your receiver can detect the strong signal from the transmitter but not the weaker reflections. Flat black paint may also be your friend here. 😊